



Deployed Around the World

RAPID DEPLOYMENT TACTICAL CONTAINERS

At the heart of any successful mission, especially when lives are on the line, military units must rely on equipment that will work without failure. Tactical containers are core to this vital life line.



FEATURES:

- Up to 8,500 lbs (3,850 kilos) cargo capacity
- Reinforced aluminum frame and extrusions combined with high impact resistance composite panels
- Collapsible to 32 inches (82 cm) under 5 minutes by two people without tools
- Fully airworthiness certified for transport in fixed wing and rotary wing aircraft
- Seamless end-to-end movement (can be tied down directly to aircraft floor or truck bed)
- Fully maintainable / repairable / replaceable parts
- Interior configurable for multiple uses using factory installed floor tracks
- Two and four-way forkliftable



Norduyn is a designer and manufacturer of engineered and airworthiness-certified products for military aviation markets. Norduyn's products support highly mobile troops with equipment that is designed to be intermodal with a high degree of survivability.



Norduyn's rapid deployment containers are proven to be a robust, practical end-to-end mobility solution enabling the efficient transportation of essential equipment in support of missions.

KEY ADVANTAGES



Norduyn Containers

- Enables rapid deployment of troops
- Fully rated air transportable / slingable
- Saves space: collapsible when empty
- 40% lighter than conventional containers
- Highly resistant to impacts – tested to 10,000 lbs (4,500 kg) impact on walls and doors
- Maintainability: Any damaged part can be repaired or replaced on location
- Water resistant
- Adaptable interior design for specialty uses such as transport of high-end electronics systems

OPERATIONAL ADVANTAGES

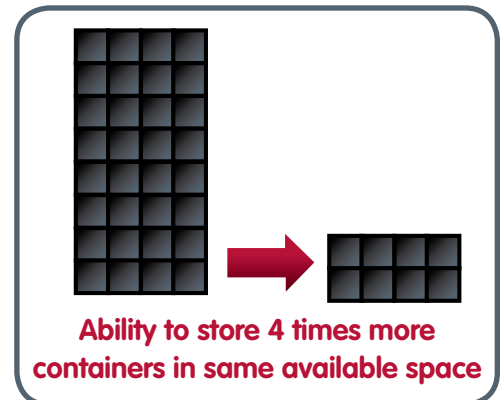
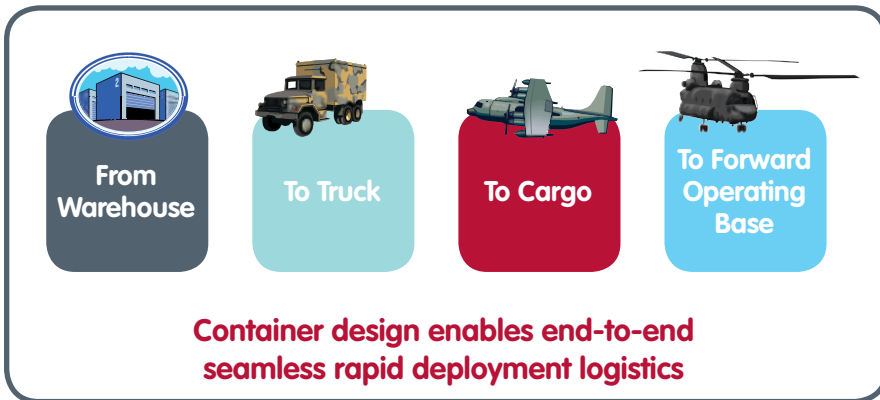

Collapsible in less than 5 minutes to save valuable space for cargo aircraft transport or warehousing



ECO-RESPONSIBLE PROGRAM

Norduyn is committed to reducing its carbon footprint. All containers were developed with sustainability as a key development parameter:

- **Lighter containers:** Norduyn containers are 40% lighter than conventional metal containers with a higher strength to weight ratio
- **Saves aircraft fuel and warehousing space:** They are collapsible to 32 inches (80 centimeters) enabling piling and efficient air lifting of empty containers (saves on the number of trips an aircraft must make to transport conventional containers)
- **Survivable, maintainable:** All parts are repairable and fully recyclable



Sustainable Air Logistics Program

Committed to protecting our environment

Norduyn customers benefit from our company's unique parts exchange and recycling program where Norduyn will take back damaged parts and wall panels that cannot be repaired by the users and exchange them against a new or refurbished part. This unique sustainability program ensures that each container remain a useful part of troop and material deployment for several years of operations.

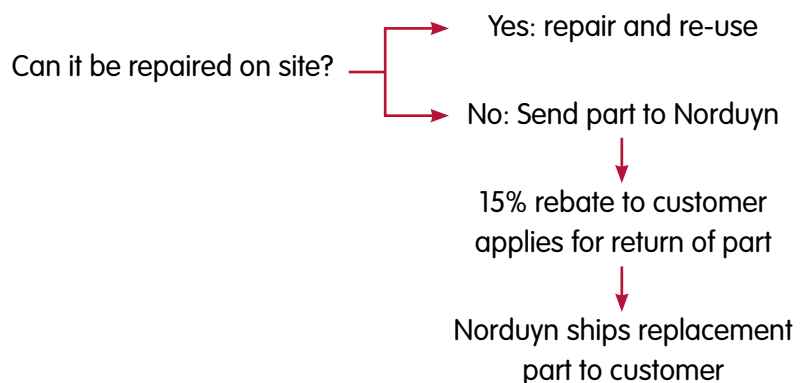
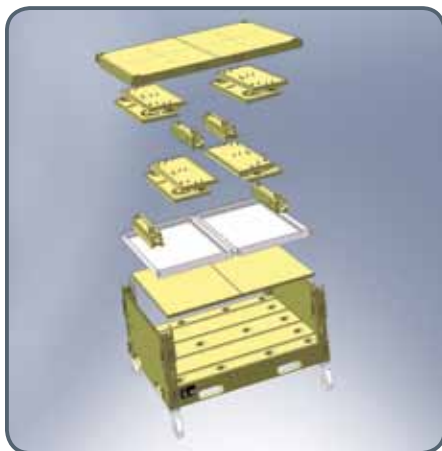



Product Specifications

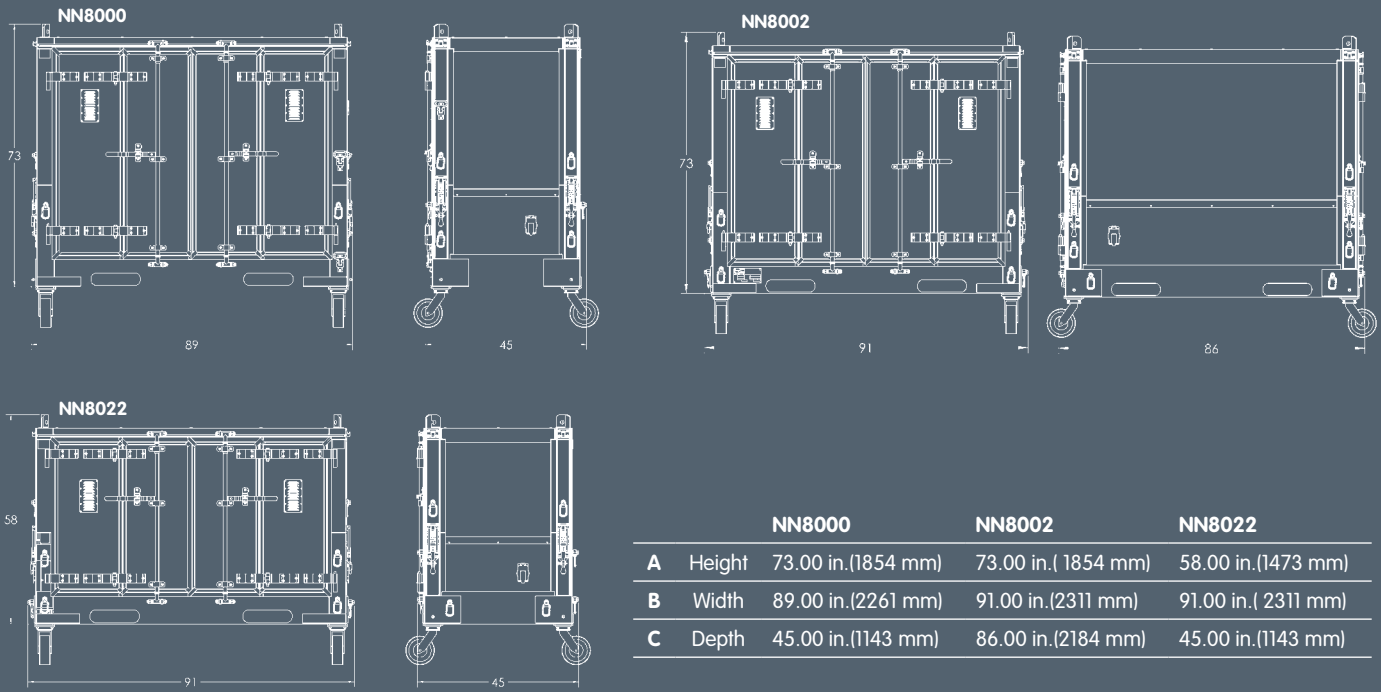

Patent Pending

Airworthiness Certification:

Norduyn containers received certification from the US Naval Air Warfare Center, Aircraft Division (NAVAIR) for air transport.

About Norduyn:

Founded in 1933, Norduyn is involved in the design, certification and manufacturing of innovative product solutions for aviation markets. Norduyn specializes in high performance composites and holds several patents for recent innovations. The company's ingredients for success include a high level of technical know-how in light weight composite technologies, and over 50 years of regulatory expertise enabling timely certification of new product solutions. Norduyn is quality certified AS9100 and ISO9001.



Contact us
lbienville@norduyn.com
Mr. Leonce "Bean" Bienville

25465 SE 275 PL Maple Valley, WA 98038
www.norduyn.com
1-206-498-5824